

Plan View

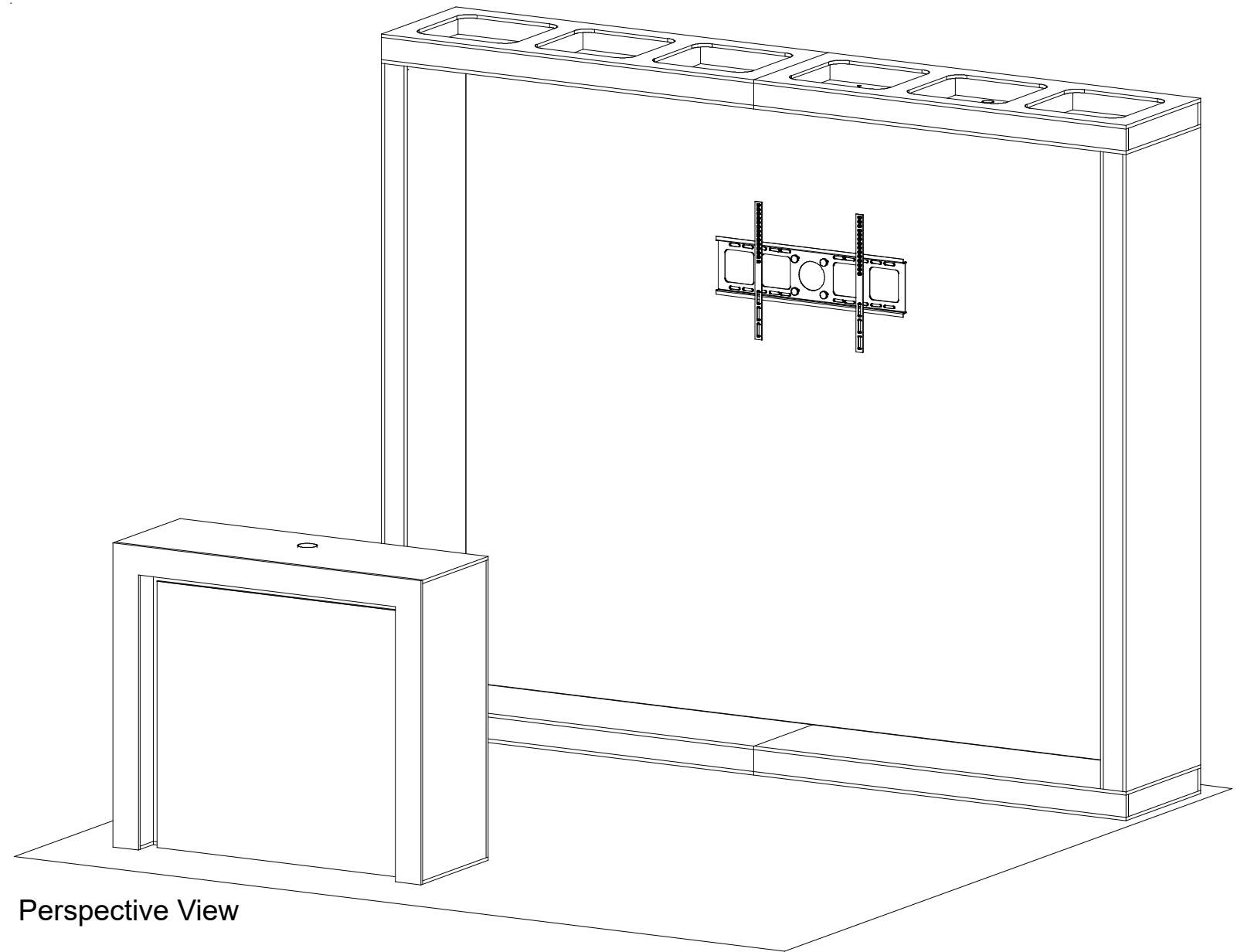

SETUP INSTRUCTIONS

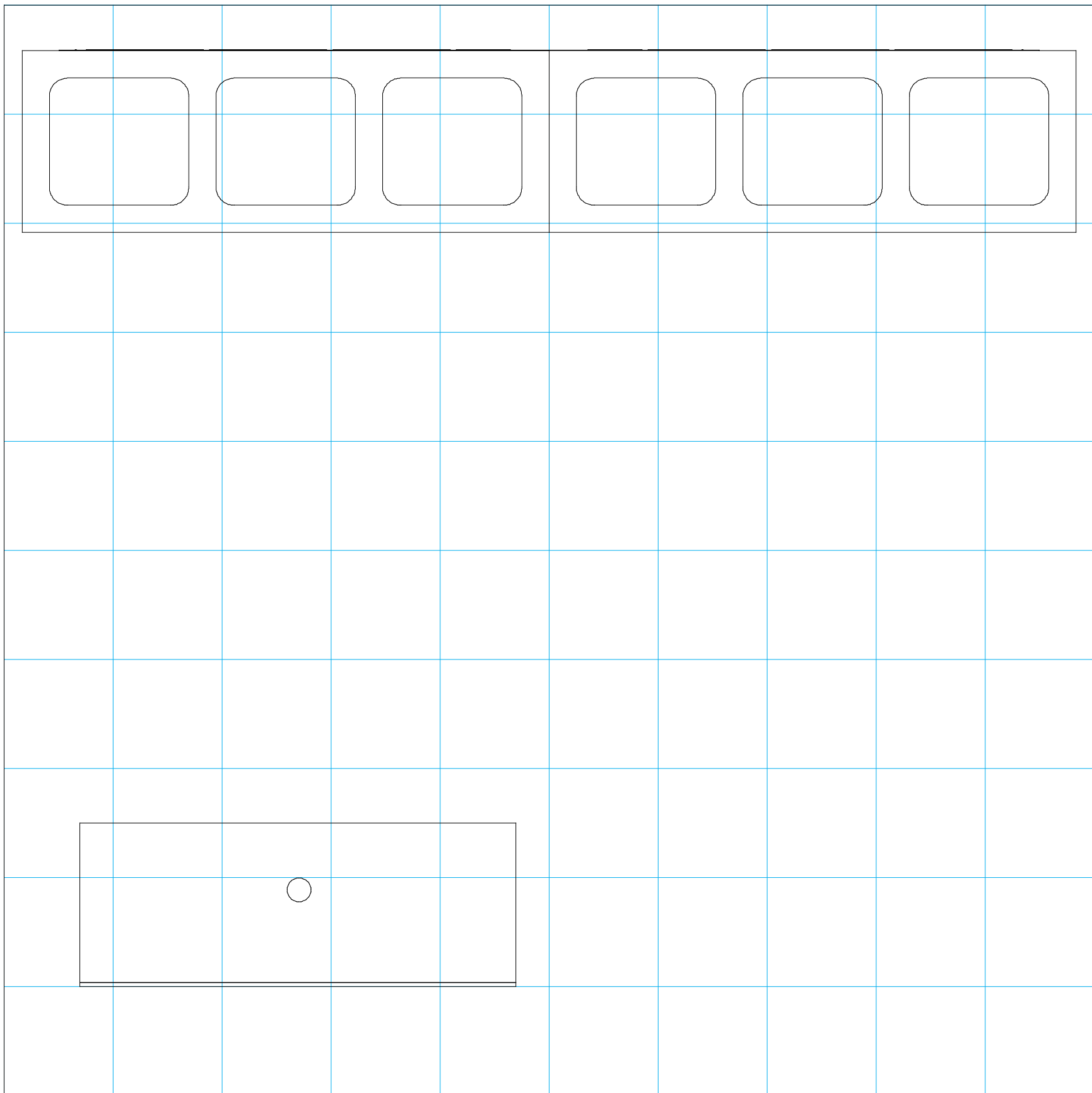

= 1 sq foot

General Setup Instructions

- Read entire setup instruction manual prior to unpacking parts and pieces.
- The setup instructions are created specifically for this configuration.
- Setup instructions are laid out sequentially in steps, including exploded views with detailed explanation for assembly.

Cleaning & Packing

- For Cleaning Metal, Plex, & Laminate Parts: Use a **MILD NON-ABRASIVE** cleanser and soft cloth/paper towel to clean all surfaces.
- Keep exhibit components away from heat and prolonged sun exposure.
Heat and UV exposure will warp and fade components.
- Retain all provided Packing Materials. All provided packing materials are for ease of repacking & component protection.

Disassembly

- For loss prevention, tighten all set screws and locks during disassembly.

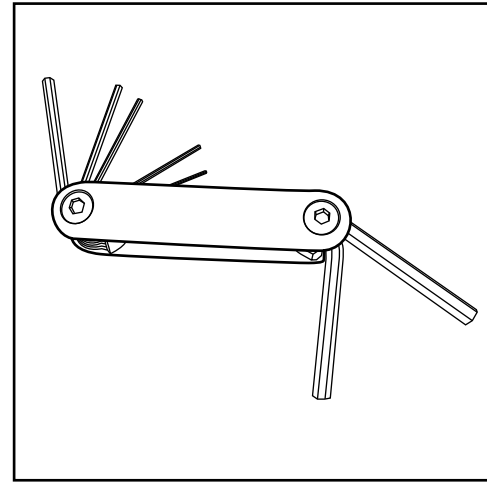

Hex Tool - Essential for Assembly

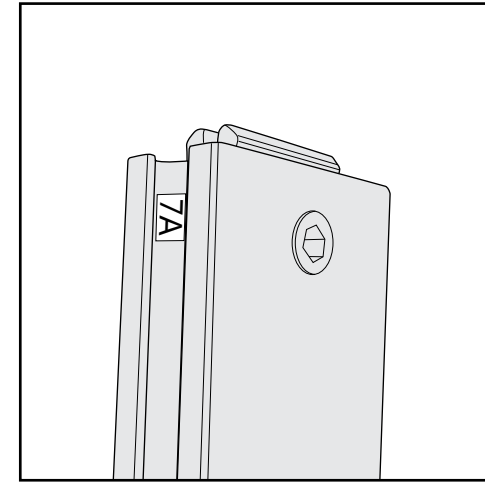

Part Identification - Numbering

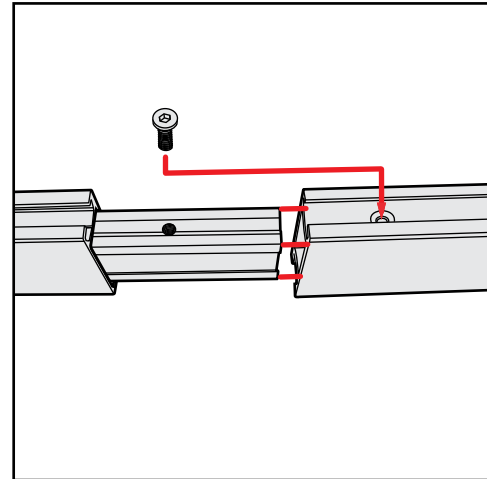

Spline Connection

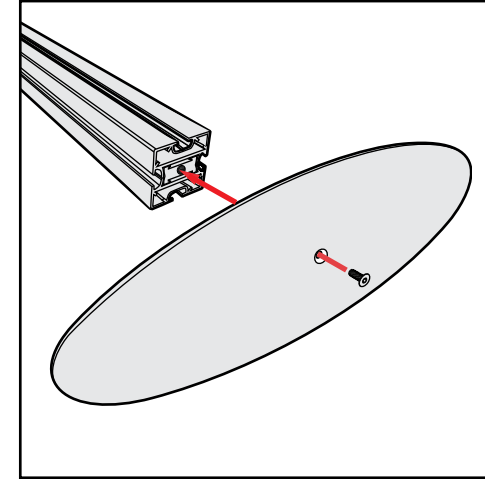

Base Plate & Extrusion Connection

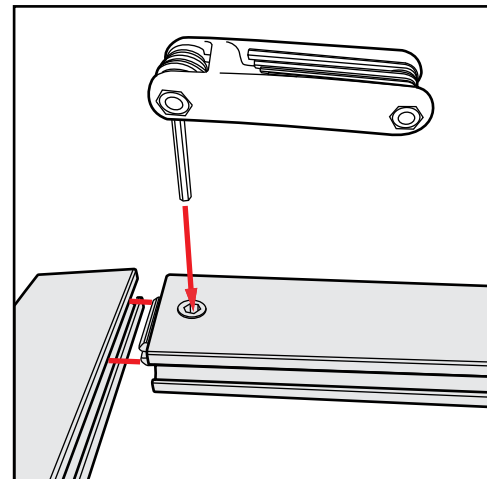

Extrusion & Lock Connection

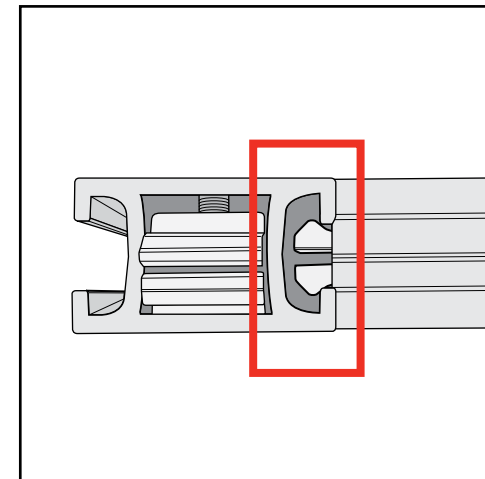

Engaged Lock



WARNING

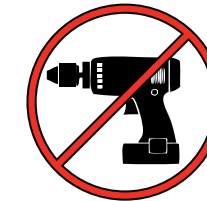

DO NOT USE POWER TOOLS

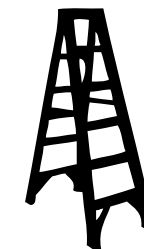

LADDERS OR LIFTS
MAY BE REQUIRED



ALL CONNECTIONS MUST
BE TIGHTLY SECURED

Straight Connection

When assembling frame, first attach all **straight connectors**, then attach **corner connectors**.

- 1) Place extrusions end-to-end.
- 2) Loosen all knobs, then slide **straight connectors** across the seam of extrusions.
- 3) Tighten all knobs to secure connection.

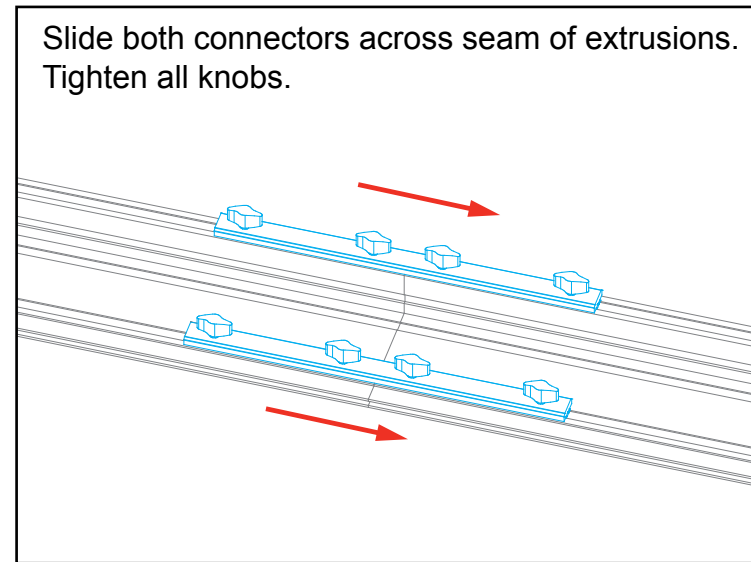
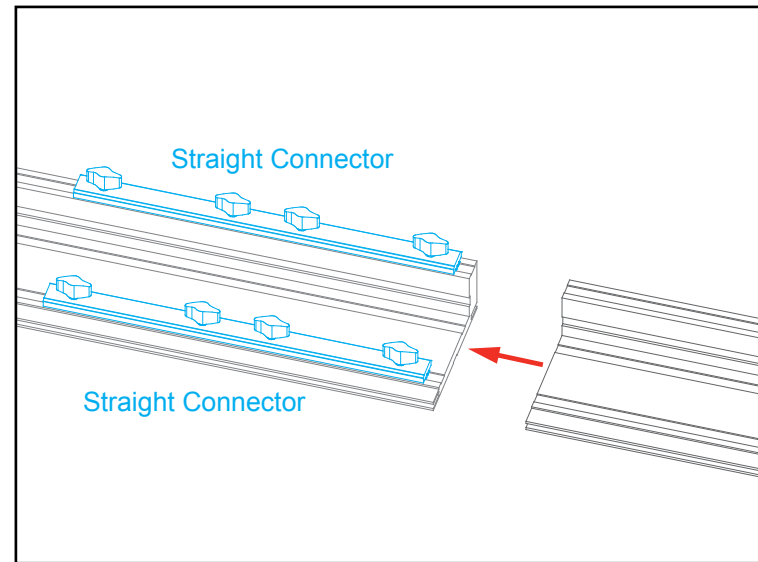

All knobs must be tightened securely to ensure a proper connection.

Disassembly

- 1) Loosen all knobs.
- 2) Slide connectors off of one extrusion.
- 3) Tighten knobs to prevent loss during packing & shipping.

Keep straight connectors in groove of extrusion. Do not remove connectors during disassembly.

Corner Connection

- 1) Loosen knobs, then slide vertical extrusions onto **corner connectors** of **lower** horizontal extrusion.
- 2) Slide **corner connectors** of **upper** horizontal extrusion into grooves of vertical extrusions.
- 3) Tighten all knobs to secure connection.

Disassembly

- 1) Loosen knobs on vertical extrusions.
- 2) Slide the vertical extrusions off of **corner connectors** on lower and upper horizontal extrusions.

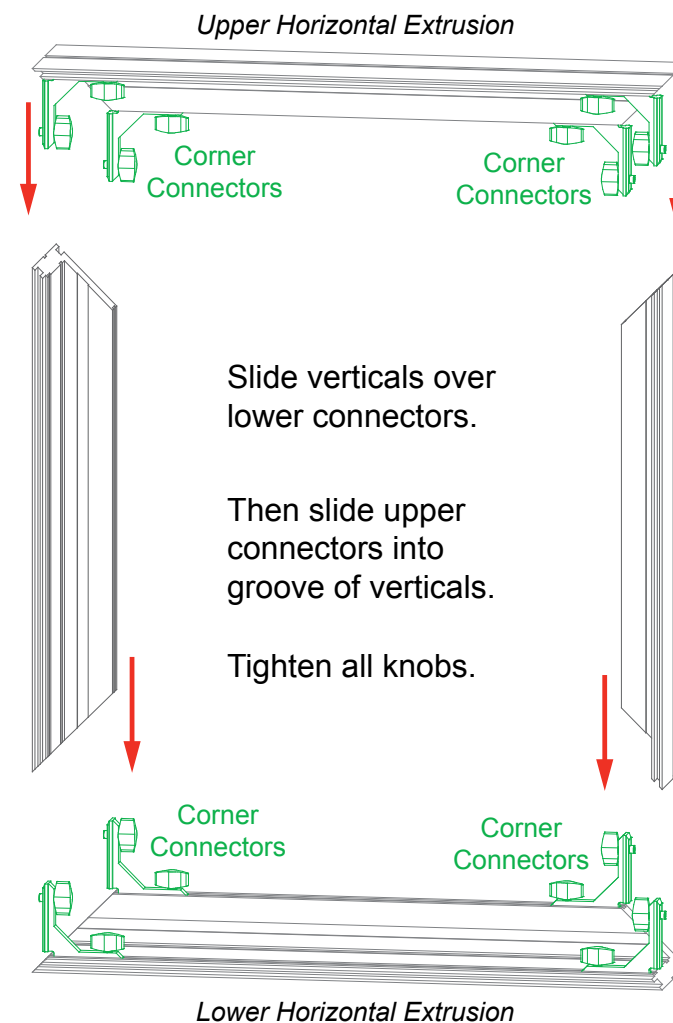

Adjust connectors if necessary to prevent gaps in connection.

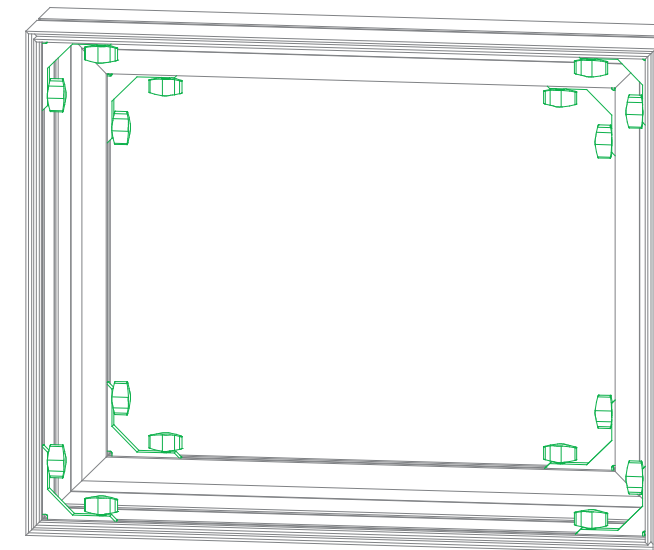

COMPLETED ASSEMBLY

All knobs must be tightened securely to ensure a proper connection.

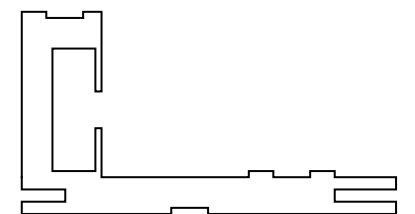

CEI110 Profile

SEG Graphic Installation *in 3 Steps*

The Perfect Fit

STEP 1: Attach Corners

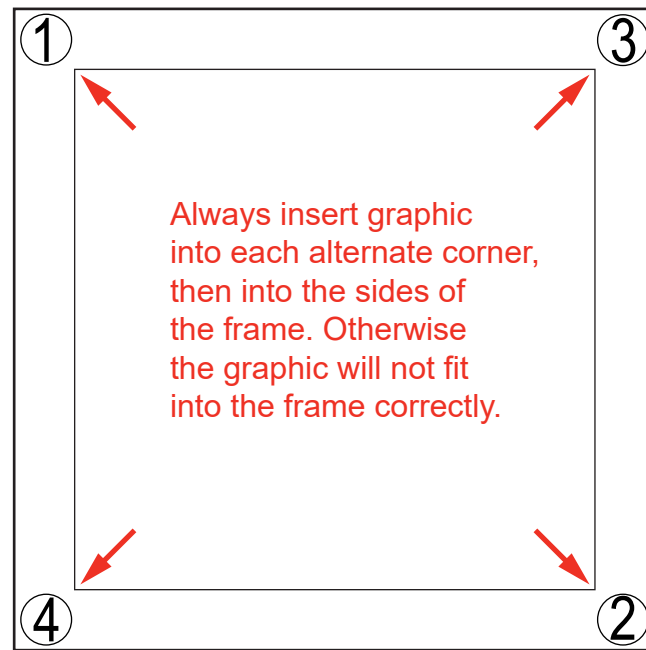

STEP 2: Attach Middle

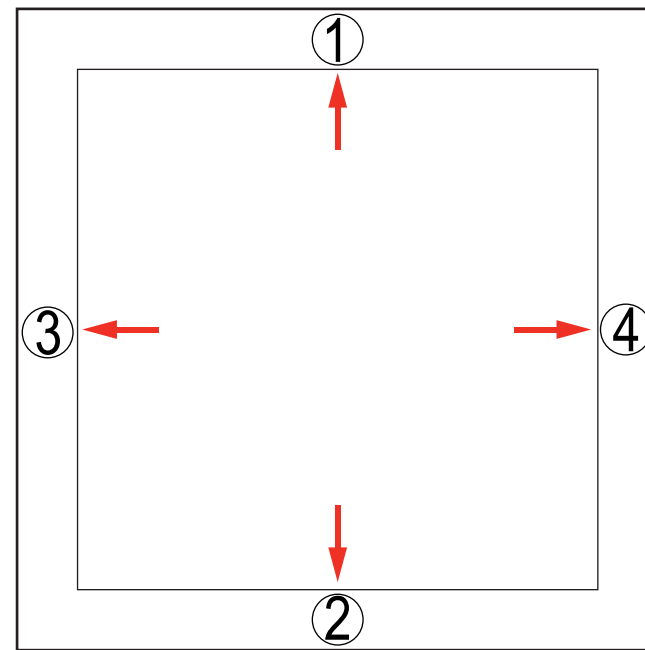

STEP 3: Attach Sides

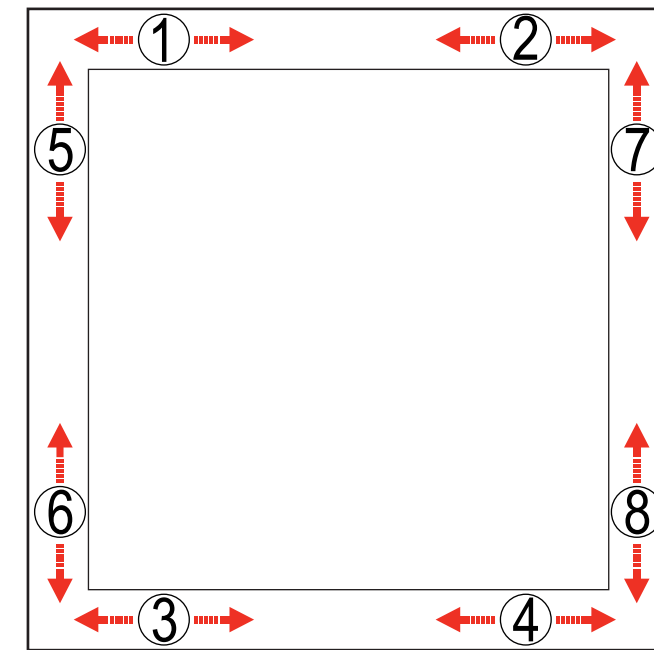

Insert narrow side of silicone welt into the channel at corner 1, with fabric to the outside.

Repeat for opposite corner 2, then corner 3, then corner 4.

Once corners are attached, press the middle of edge 1 into the channel. Then press middle of edge 2 into the channel on opposite side.

Repeat with edge 3 & 4.

Once the middle of sides are attached, fully press the silicone welt into the channel, between center and corner at location 1. Repeat the process between center and corner at location 2.

Do the same for welt on opposite side, at locations 3 & 4. Then repeat for locations 5 & 6 and 7 & 8.

Once the welt is fully inserted on all sides, smooth out edges as needed for a perfect fit.



To remove the graphic from the frame, locate the fabric **pull tab**. Gently pull on the tab to remove the graphic.

Install video:



CRATE PACKING

Item	Qty.	Description
1	1	88”h CEI110 Vertical Extrusion
2	1	88”h CEI110 Vertical Extrusion
3A,3B	1,1	54”w CEI110 Horizontal Extrusion
4A,4B	1,1	54”w CEI110 Horizontal Extrusion
5	1	84.353”h Z140 Vertical Extrusion

Steps:

- 1) Connect horizontals [3A to 3B] and [4A to 4B].
See [CEI-110 Straight Connection](#) detail.
- 2) Attach horizontal assemblies [3A/3B] and [4A/4B] between verticals [1] and [2].
See [CEI-110 Corner Connection](#) detail.
- 3) Attach standoffs to vertical [5] then attach [5] between horizontal assemblies.
- 4) Connect lighting cords and attach transformers.
See [Light to Light Connection](#) & [Light to Transformer Connection](#) details.

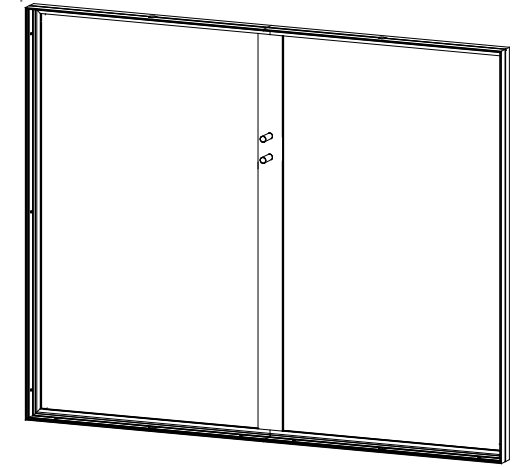

Completed Assembly

Assemble frame flat on ground.

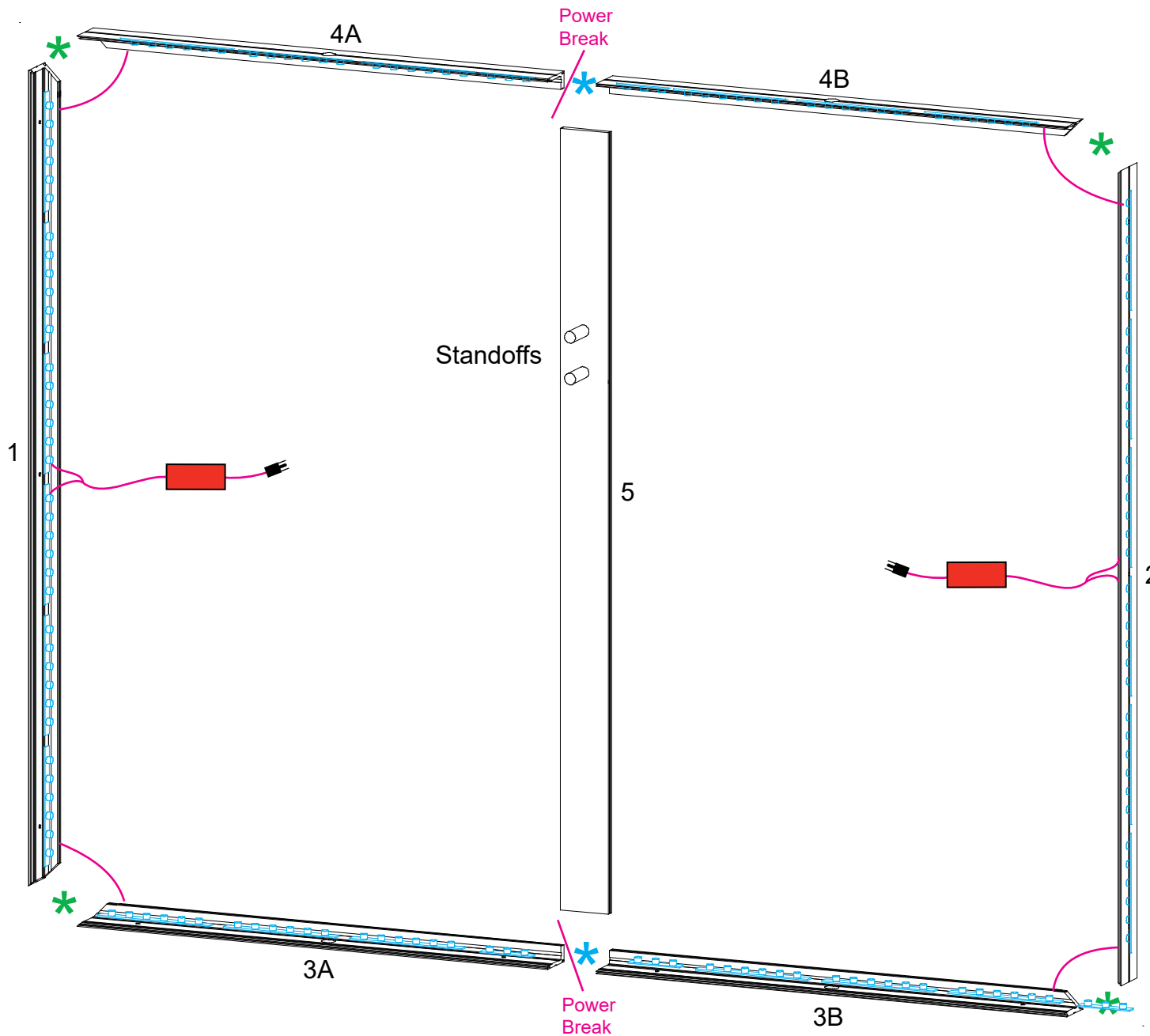

*** CEI-110 Straight Connection**

1. Place extrusions end-to-end.
2. Slide connectors across seam of extrusions.
3. Tighten all knobs to secure connection.

*** CEI-110 Corner Connection**

1. Slide extrusion onto corner connectors.
2. Tighten all knobs to secure connection.

Light to Light Connection

Light to Transformer Connection

Maximum of 12 lights per transformer.

Item	Qty.	Description
D/D1	1/1	58"w x 20"d x 4" Wood Ceiling
E/E1	1/1	88"w x 20"d x 4" Wood Ceiling
G/G1	1/1	58"w x 20"d x 4" Wood Ceiling

- Steps:
- 1) Assemble wood panels as shown. See **Cam Lock Connection** detail.
 - 2) Attach assembled lightbox to wood panels using washers & bolts.
 - 3) Install SEG graphic to assembled lightbox.
See SEG Graphics Installation sheet for details.
 - 4) Attach monitor mount to standoffs on extrusion [5] using caps.

*** Cam Lock Connection**

Step#1

Step#2

Place hex tool in hole on side of panel, then turn tool to activate lock into connecting panel.

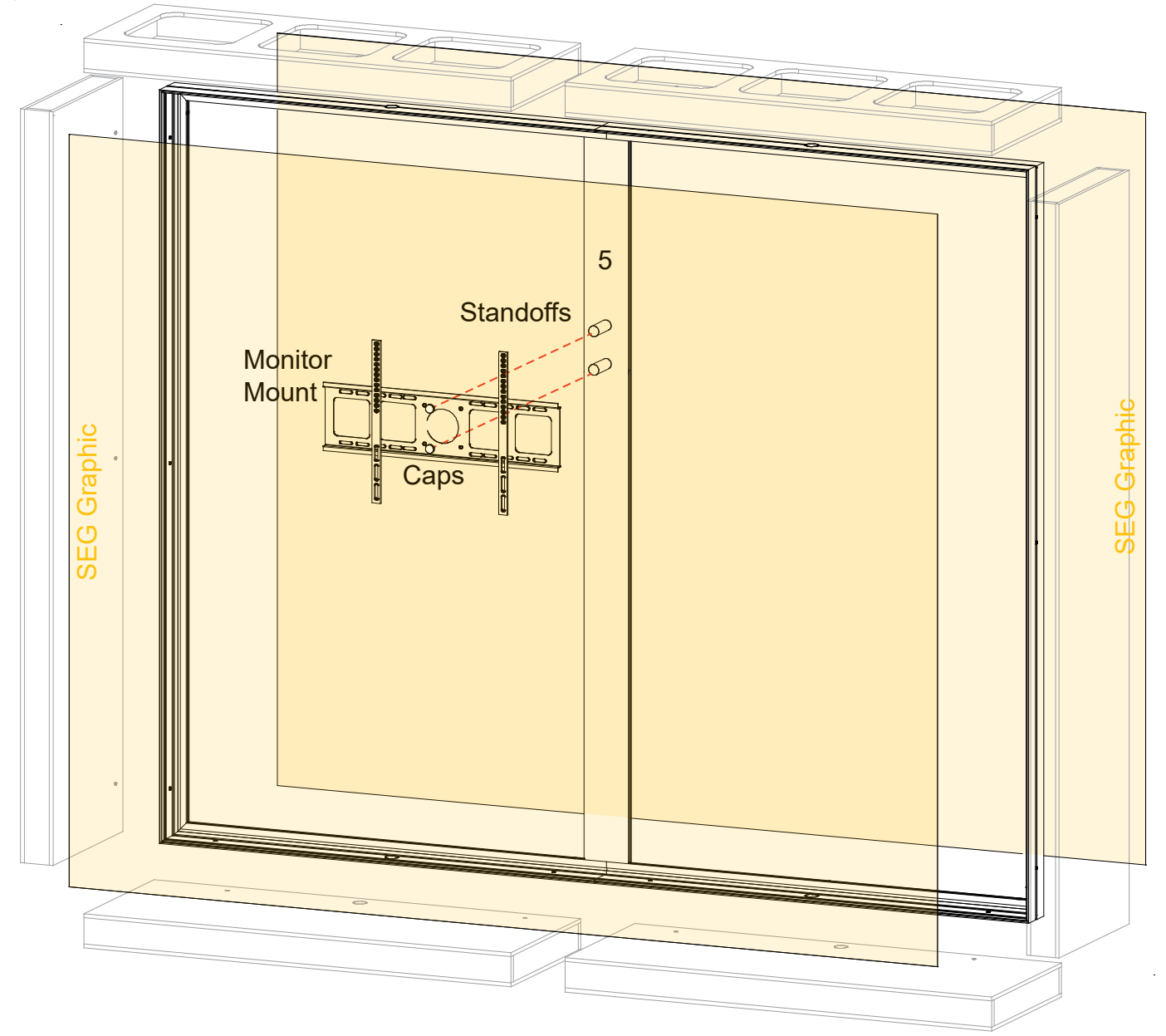
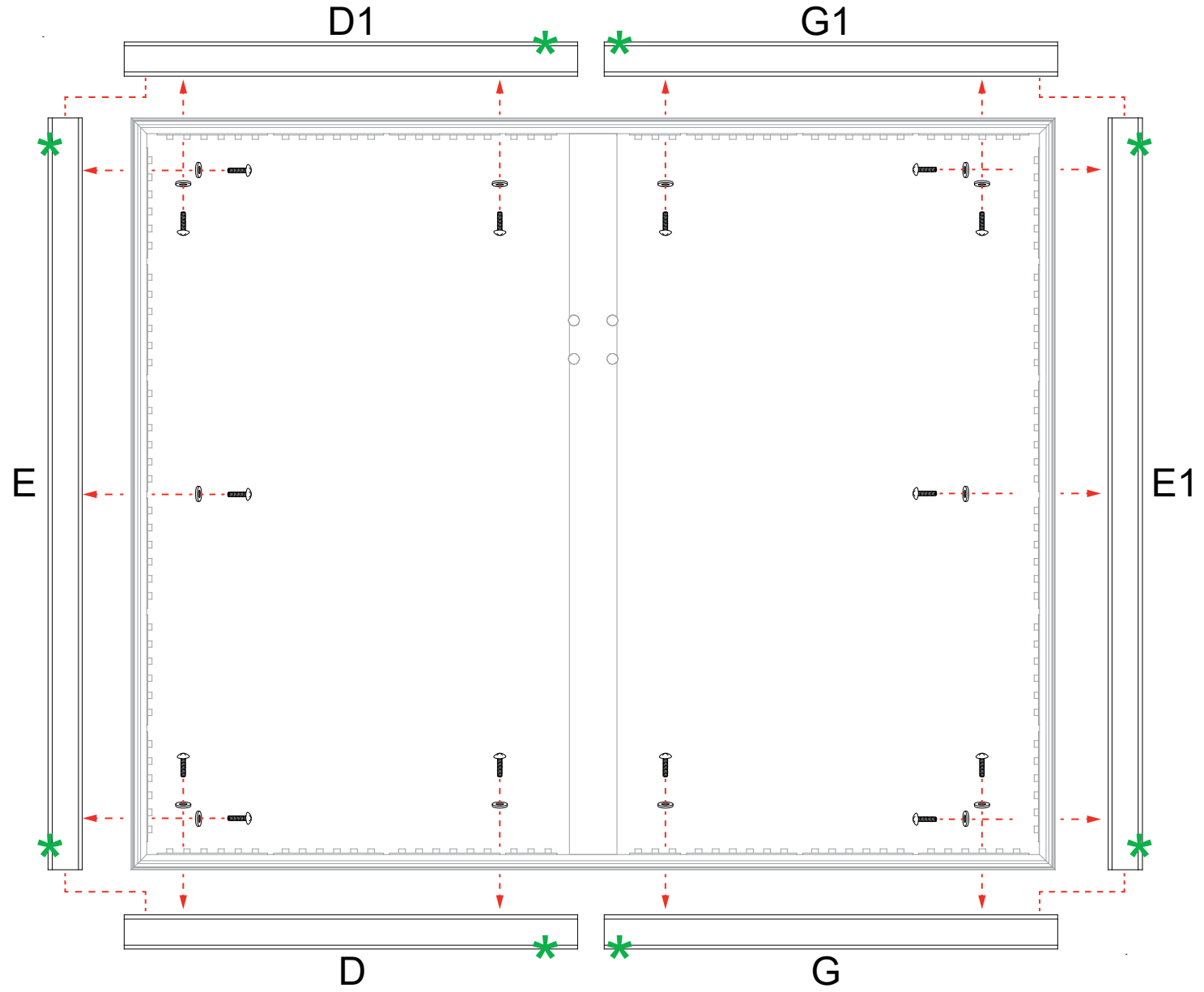

Steps:

- 1) Attach transformer. See [Light to Light Connection](#) & [Light to Transformer Connection](#) details.
- 2) Route cord thru hole in base of counter then connect to power.



Optional Lighting

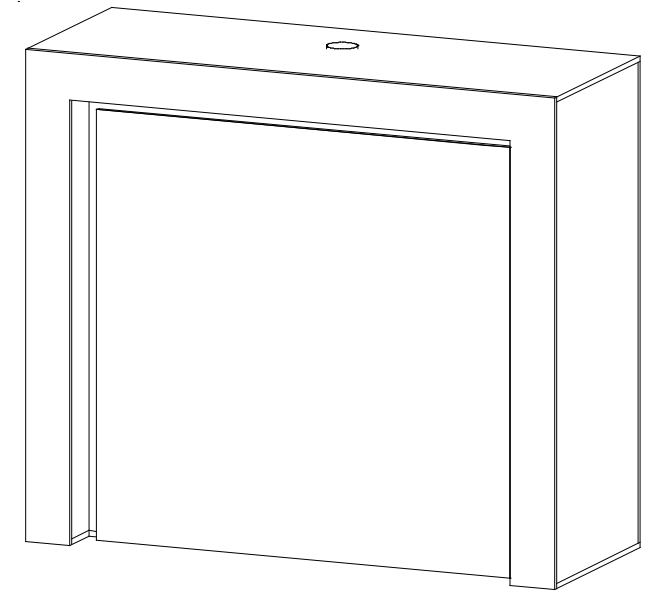

Completed Assembly

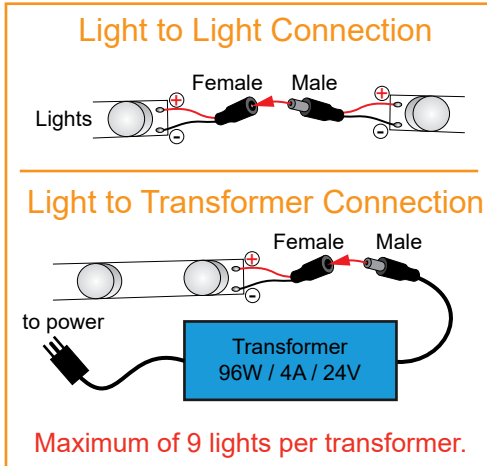

All cords and transformer stay attached.

